

Strain Gauge Retrofit Procedure

for Kit PN PBT-0110

for the PBFT

Use these instructions and a Strain Gauge Retrofit Kit (PN PBT-0110) to replace either of the following older models with the new 2 LBF Black Strain Gauge (PN 2900-0005):

- X-3234 strain gauge (PN 10/0287)
- 2 LBF White Strain Gauge (PN 10/4052)

NOTE: These instructions do not apply to the replacement of any other version of strain gauge.



Scope of Supply

A kit will typically include the following items:

- 2LBF Black Strain Gauge
- Strain Gauge Mount
- Battery Charger
- Power Adapter
- Tape Clamp Assembly
- Instruction Sheet

Retrofit Procedure

1. Remove Old Strain Gauge

To remove either model of old strain gauge from the PBFT:

1. Disconnect both the battery charger and communications cables from the old strain gauge.

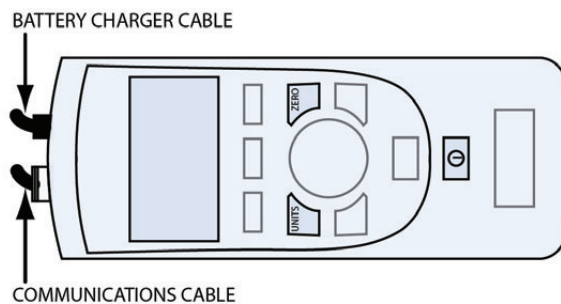

2. Remove the strain gauge from the PBFT by removing the two mounting screws from the underside of the mounting plate to which the strain gauge is secured. Set screws aside for use during installation of the new strain gauge.

2. Remove Mount Plate

If an old style mount plate is in use, it will need to be replaced to maintain proper peel angle.

1. Inspect the PBFT to discover which mount plate is currently in use:
 - If the new, thicker (1") mount plate is already in use, skip to [4. Align Tape Clip](#) (pg 3).
 - If the old model (0.18" thick) is in use, it will need to be replaced with the new (1" thick) model included in the kit. Go to step 2.

Only the NEW style mount plate should be used with the new strain gauge model

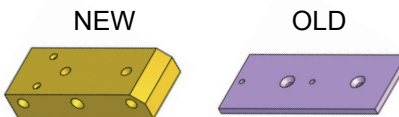

2. Remove the old style mount plate:
 - a. Remove all power from the PBFT.
 - b. To expose the Collar securing the strain gauge Adjustment Screw, remove the screws in the Top Cover using a 3/32" Allen wrench, and then, being **careful not to put tension on the ground wire attached to the cover**, slide the Top Cover back away from the front cover .

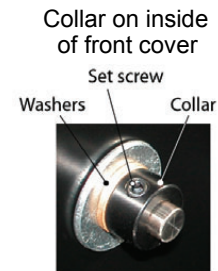
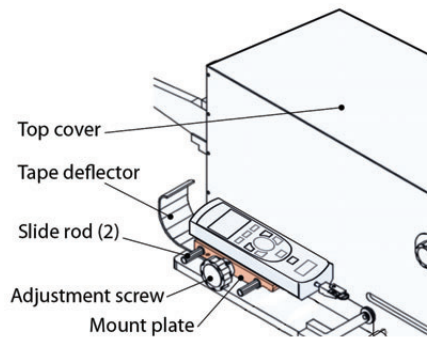

- c. Loosen the Set Screw in the Collar using a 5/64" Allen wrench, slide the Collar and Washers off of the Adjustment Screw and set them aside.
- d. Pull the Adjustment Screw and Mount Plate away from the front of the PBFT and off the Slide Rods.
- e. Unscrew the Adjustment Screw and Tape Deflector from the old mount plate and set both items aside.

3. Install New Strain Gauge

1. Mount the tape deflector and strain gauge to a new mount plate:
 - a. Mount the Tape Deflector to the new mount plate from the kit with (2) 8-32x3/8" flathead screws.
 - b. Mount the new style mount plate to the back of the new strain gauge with two (2) 10-32x5/8" socket head screws.
2. Install the new strain gauge assembly on the PBFT:
 - a. Screw the Adjustment Screw into the center hole in the mount plate.
 - b. Slide the mount plate and Adjustment Screw assembly onto the PBFT Slide Rods so the mount plate is seated flush against the front cover of the PBFT
 - c. Slide the Washers and Collar onto the end of the Adjustment Screw now protruding into the interior of the PBFT.
 - d. With the Set Screw seated on the flat surface of the Adjustment Screw rod, tighten the Set Screw in the Collar.
 - e. Slide the Top Cover back into place on the PBFT and secure it in place.

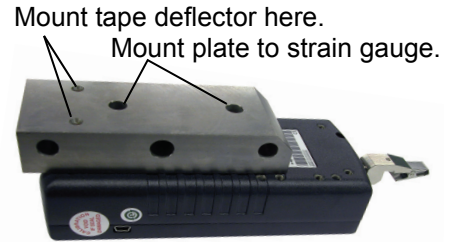

4. Align Tape Clip

Verify that the strain gauge Tape Clip is square to the PBFT Base Plate. As needed, loosen the set screw in the tape clip with a 0.050" Allen wrench, adjust tape clip orientation, then retighten the set screw so the tape clip is locked in place.

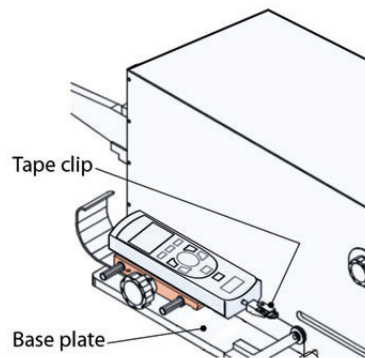

5. Connect Strain Gauge

1. Connect the PBFT communications cable to the new strain gauge.

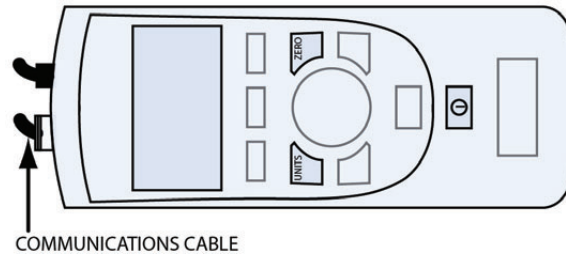

2. Refer to the voltage chart below, decide which battery charger equipment is appropriate for your power source, and then follow the chart instructions for your voltage choice.

110V	<p>Battery Charger</p>	<p>For 110 volt power, use the battery charger included in the kit. Connect the cable end to the strain gauge. Plug the power outlet end into a power source.</p>
220V	<p>Battery Charger Power Transformer</p>	<p>For 220 volt power, connect the battery charger included in the kit to a customer supplied 220 V to 110 V power transformer. Connect the cable end of the battery charger to the strain gauge. Plug the power outlet end of the power transformer into a power source.</p>

3. Connect the new battery charger cable to the strain gauge.

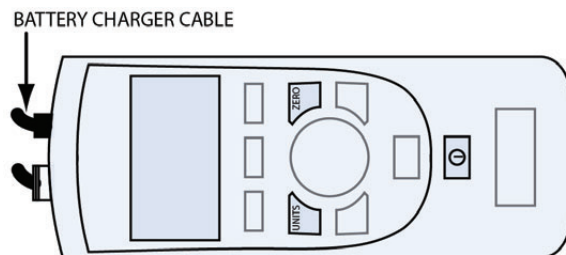

NOTE: The original battery charger cable should remain disconnected as it will no longer be used.

Strain gauge replacement is now complete.